

Troubleshooting Chart:

Problem	Cause	Solution
1. No discharge	a. No water b. Magnetic valve not functioning c. Excessive water pressure d. Eductor clogged e. Clogged water inlet strainer	a. Open water supply b. Install valve parts kit c. Install regulator if water pressure exceeds 60 PSI (flowing) d. Clean* or replace e. Disconnect inlet water line and clean s strainer
2. No concentrate draw	a. Clogged foot valve b. Metering tip or eductor has scale build-up c. Low water pressure d. Discharge tube and/or flooding ring not in place e. Concentrate container empty f. Inlet hose barb not screwed into eductor tightly g. Clogged water inlet strainer h. Air leak in chemical pick-up tube	a. Clean or replace b. Clean (descale)* or replace c. Minimum 20 PSI (with water running) required to operate unit properly d. Push tube firmly onto eductor discharge hose barb, or replace tube if it doesn't have a flooding ring. e. Replace with full container f. Tighten, but do not overtighten g. Disconnect inlet water line and clean strainer h. Put clamp on tube or replace tube if brittle
3. Excess concentrate draw	a. Metering tip not in place b. Chemical above eductor	a. Press correct tip firmly into barb on eductor b. Place concentrate below the eductor
4. Failure of unit to turn off	a. Water valve parts dirty or defective b. Magnet doesn't fully return c. Push button stuck	a. Clean* or replace with valve parts kit b. Make sure magnet moves freely. c. Remove button and clean cabinet/button to remove any dirt lodged in slide recess
5. Excess foaming in discharge	a. Air leak in pick-up tube	a. Put clamp on tube or replace tube if brittle

*In hard water areas, scale may form inside the discharge end of the eductor, as well as in other areas of the unit that are exposed to water. This scale may be removed by soaking the eductor in a descaling solution (deliming solution). To remove an eductor located in the cabinet, firmly grasp water valve and unthread eductor. Replace in same manner. Alternatively, a scaled eductor can be cleaned (or kept from scaling) by drawing the descaling solution through the unit. Operate the unit with the suction tube in the descaling solution. Operate the unit until solution is drawn consistently, then flush the unit by drawing clear water through it for a minute. Replace concentrate container and put suction tube into concentrate.



**AccuDose Series Proportioner
with E-Gap Eductor
For 1,2 & 3 Button Units**

Package Should Contain:

1. Proportioner unit.
2. Supply tubing.
3. Foot valve assembly & weight for each eductor.
4. Discharge tube for each eductor.
5. Metering tip kit(s).
6. Mounting anchor kit.
7. Hook(s) for discharge tube(s) -- Models with 3.5 GPM eductors only.
8. Instruction sheet.

THANK YOU FOR YOUR INTEREST IN OUR PRODUCTS

Hydro Systems manufactures quality chemical proportioning equipment. Please use this equipment carefully and observe all warnings and cautions.

*****NOTE*****

WEAR	protective clothing and eyewear when dispensing chemicals or other materials.
ALWAYS	observe safety and handling instructions of the chemical manufacturers.
ALWAYS	direct discharge away from you or other persons or into approved containers.
ALWAYS	dispense cleaners and chemicals in accordance with manufacturer's instructions. Exercise CAUTION when maintaining your equipment.
KEEP	equipment clean to maintain proper operation.
WEAR	protective clothing and eyewear when working in the vicinity of all chemicals, filling or emptying equipment or changing metering tips.
ALWAYS	re-assemble equipment according to instruction procedures. Be sure all components are firmly screwed or latched into position.
ATTACH	only to tap water outlets (85 PSI maximum).
NOTE	If the unit is used to fill a sink or the discharge hose can be placed into a sink, the unit must be mounted so that the bottom of the cabinet is above the overflow rim of the sink.

Installation and Operation:

1. Remove cabinet cover. Drill holes for the three wall anchors with a 5/16" drill bit, using the cabinet back as a template for proper spacing of the mounting screws. Install mounting anchors, and then screws in top two anchors. Slide key holes in cabinet back over screw heads, tighten screws, then install bottom screw. Do not mount more than 6 feet (1.8 meters) above the bottom of the concentrate container, nor below the highest concentrate level (never mount your concentrate higher than the proportioner).
2. Select a metering tip, and insert into hose barb on eductor body. (Repeat for all eductors.)
3. Cut supply tubing provided into separate supply tubes for each product to be dispensed. Supply tubes should reach from hose barb on eductor to bottom of the concentrate container. Slide a ceramic weight over one end of tube and slide a foot valve into the same end of the tube. (Prepare a tube for each eductor.)
4. Slip other end of supply tube through an opening in either side of the cabinet and push over the hose barb/metering tip on the eductor. (Repeat for all eductors.)
5. Place foot valve ends of supply tubes into concentrate containers. REMEMBER TO CHECK FOOT VALVE STRAINERS PERIODICALLY FOR CLOGGING: CLEAN IF NECESSARY.
6. A short discharge tube is used with the 1GPM eductor; minimum tube length is 8 inches (20cm) for proper operation. Longer tubes (4 feet) are used with a 3.5 GPM eductor. Do not remove the flooding rings from inside the tubes. Slide end of tube with flooding ring over eductor discharge outlet. (Repeat for all eductors.) Hooks may be installed on longer tubes to allow discharge tube to conveniently hang from dispenser when not in use.
7. Replace cabinet cover. Push the sides in, behind the latch holes, to snap the cover in place. The two screws provided may be installed in the holes in the cabinet sides to prevent easy removal of cover.
8. Connect water supply hose of at least 3/8" ID to water inlet swivel. (Minimum 25 PSI pressure, with water running, is required for proper operation.) Connect opposite end of hose to water supply. Turn water supply on.
9. Push button to start flow of desired water/concentrate solution, and hold until supply tube is primed (filled). Then push the button whenever dispensing is desired, and release button to stop flow of solution. **If you wish to be able to lock the button in the "on" position:** clip or bend the two tabs behind the lower front portion of the button (see diagram). This allows the button to be fully depressed and allows it to latch in the "on" position. **To unlock, pull the button out.**

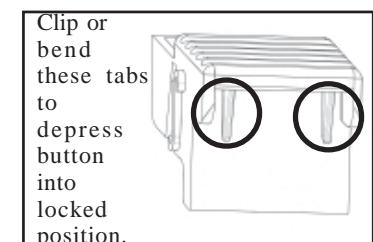

A DOVER COMPANY

3798 Round Bottom Road, Cincinnati, OH 45244 U.S.A. • Phone: (513) 271-8800 • Fax: (513) 271-0160 • www.hydrosystemsco.com

10089600
Rev. A 3/05

Metering Tip Selection:

The final concentration of the dispensed solution is related to both the size of the metering tip opening and the viscosity of the liquid being siphoned. For water-thin products, the chart at right can be used as a guideline. If product is noticeably thicker than water, consult the Measurement of Concentration Procedure below to achieve your desired water-to-product ratio. Because dilution can vary with water temperature and pressure, actual dilution achieved can only be ascertained by using the Measurement of Concentration Procedure. The clear, undrilled tip is provided to permit drilling to size not listed should you need a dilution ratio that falls between standard tip sizes.

NOTE: A 1 GPM eductor is grey; a 3.5 GPM eductor is yellow. Refer to parts diagram if unfamiliar with names of system components.

Measurement of Concentration:

You can determine the dispensed water-to-product ratio for any metering tip size and product viscosity. All that is required is to operate the primed dispenser for a minute or so and note two things: the amount of dispensed solution, and the amount of concentrate used in preparation of the solution dispensed. The water-to-product ratio is then calculated as follows:

$$\text{Dilution Ratio (X:1) where X} = \frac{\text{Amount of Mixed Solution} - \text{Amount of Concentrate Drawn}}{\text{Amount of Concentrate Drawn}}$$

Dilution Ratio, then, equals X parts water to one part concentrate (X:1). If the test does not yield the desired ratio, choose a different tip and repeat the test. Alternative methods to this test are 1) pH (using litmus paper), and 2) titration. Contact your concentrate supplier for further information on these alternative methods and the materials required to perform them.

APPROXIMATE DILUTIONS AT 40 PSI FOR WATER-THIN PRODUCTS (1.0 CP)				
Tip Color	Orifice Size	Std. Drill Number	Ratio (per Eductor Flow)	
			1 GPM	3.5 GPM
No Tip	.187	(3/16)	3:1	3.5:1
Grey	.128	(30)	3:1	4:1
Black	.098	(40)	3:1	4:1
Beige	.070	(50)	4:1	8:1
Red	.052	(55)	5:1	14:1
White	.043	(57)	7:1	20:1
Blue	.040	(60)	8:1	24:1
Tan	.035	(65)	10:1	30:1
Green	.028	(70)	16:1	45:1
Orange	.025	(72)	20:1	56:1
Brown	.023	(74)	24:1	64:1
Yellow	.020	(76)	32:1	90:1
Aqua	.018	(77)	38:1	128:1
Purple	.014	(79)	64:1	180:1
Pink	.010	(87)	128:1	350:1

**AccuDose Parts Diagram:
3-button unit illustrated**

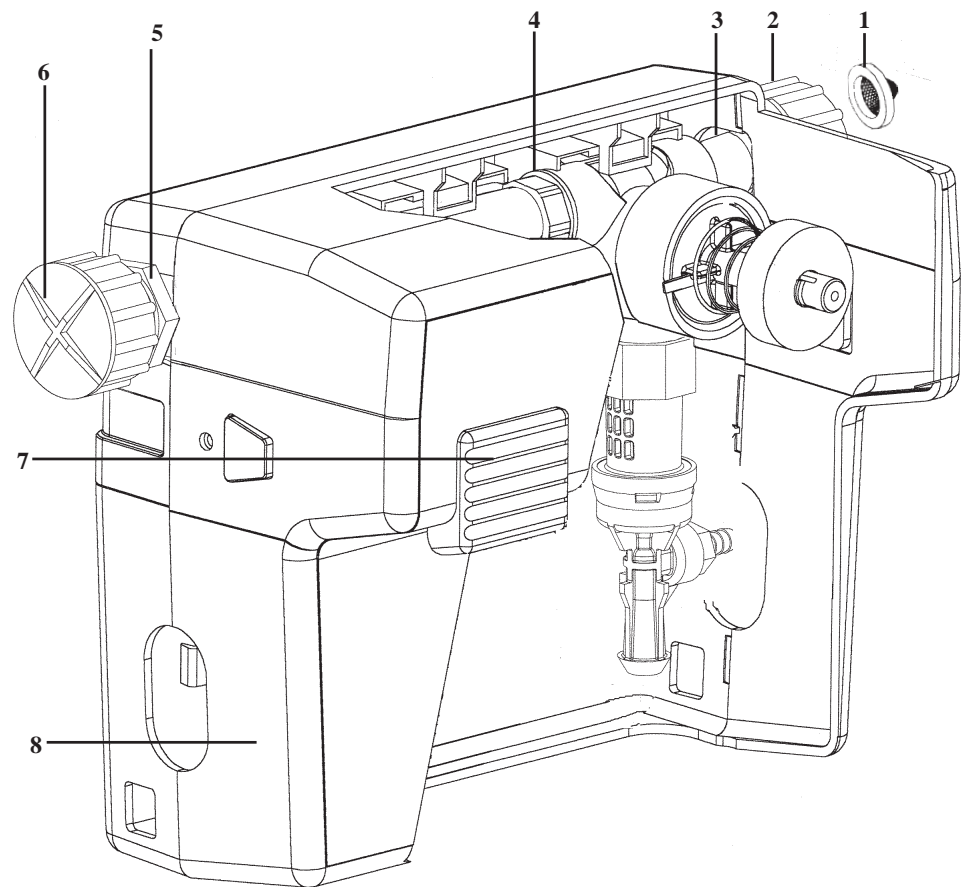

AccuDose Parts Diagram/List:

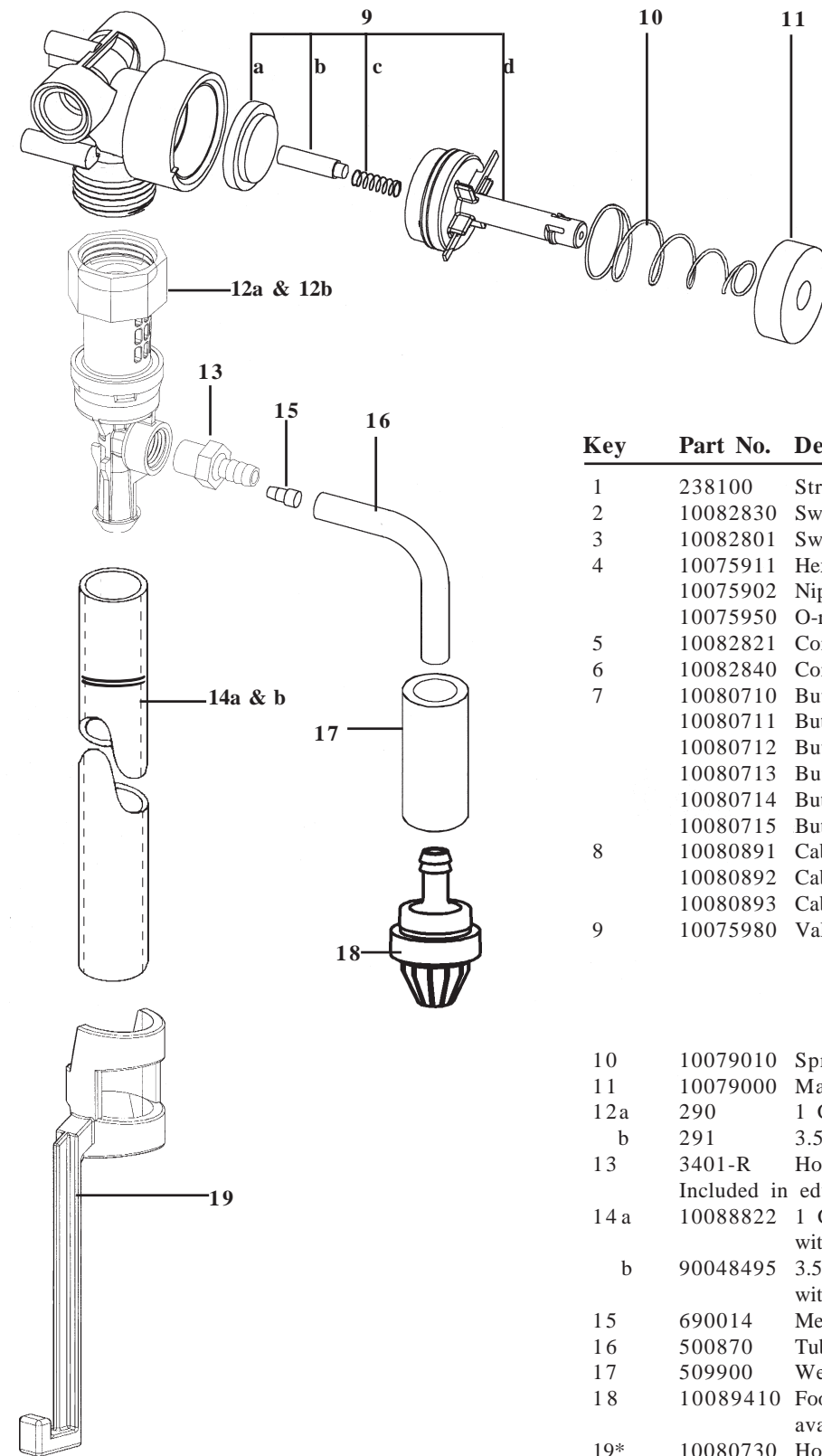

Key	Part No.	Description
1	238100	Strainer washer
2	10082830	Swivel collar (molded)
3	10082801	Swivel stem (molded)
4	10075911	Hex nipple (3-button unit only)
	10075902	Nipple (2-button unit only)
	10075950	O-ring (two required per nipple)
5	10082821	Connector fitting
6	10082840	Connector fitting cap
7	10080710	Button, dark grey (standard)
	10080711	Button, sky blue
	10080712	Button, red
	10080713	Button, green
	10080714	Button, light grey
	10080715	Button, yellow
8	10080891	Cabinet set, 1-button unit
	10080892	Cabinet set, 2-button unit
	10080893	Cabinet set, 3-button unit (shown)
9	10075980	Valve parts kit
	a.	diaphragm
	b.	armature
	c.	spring
	d.	valve bonnet
10	10079010	Spring
11	10079000	Magnet
12a	290	1 GPM eductor assembly
b	291	3.5GPM eductor assembly
13	3401-R	Hose barb assembly*
		Included in eductor assembly's
14 a	10088822	1 GPM discharge tube with flooding ring (8")
b	90048495	3.5 GPM discharge tube with flooding ring (4')
15	690014	Metering tip, kit
16	500870	Tubing 1/4" x 7'
17	509900	Weight
18	10089410	Footvalve --Vtion (EPDM also available. Order 10076302.)
19*	10080730	Hose hook, dark grey (standard)
	10080731	Hose hook, sky blue
	10080732	Hose hook, red
	10080733	Hose hook, green
	10080734	Hose hook, light grey
	10080735	Hose hook, yellow

NOT SHOWN:

641751 Security screws (for cabinet sides)